

# AIR PULL-SETTERS

## LG-803

### SPECIFICATION

Free speed(R.P.M.)600  
 Air pressure 90 psi  
 Air inlet(N.P.T.) 1/4"  
 Air consumption 5CFM  
 Thread size:M8, M10  
 Hose size: 3/8"(9.5m/m)

## LG-804

### SPECIFICATION

Free speed(R.P.M.)400  
 Air pressure 90 psi  
 Air inlet(N.P.T.) 1/4"  
 Air consumption 5CFM  
 Thread size:M8, M10  
 Hose size: 3/8"(9.5m/m)

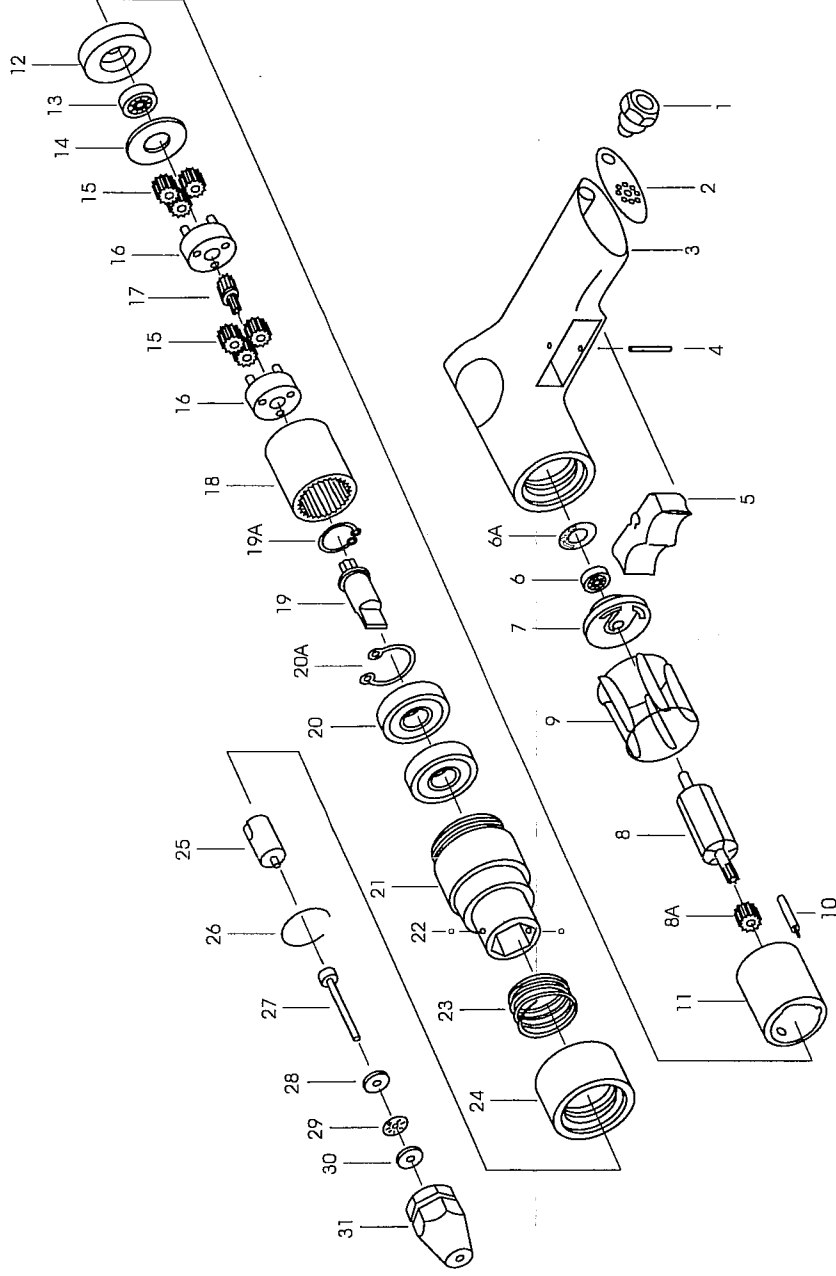

PART NO.	Description	NO. Req'd	PART NO.	Description	NO. Req'd
803-1	AIR INLET	1	803-16	GEAR CAGE	2
803-2	DIFFUSER-EXHAUST	1	804-16	GEAR CAGE	2
803-3	HANDLE	1	803-17	SUN GEAR (12T)	1
803-4	PIN (ø3x28)	1	804-17	SUN GEAR (9T)	1
803-5	TRIGGER	1	803-18	INTERNAL GEAR	1
803-6A	GASKET	1	804-18	INTERNAL GEAR	1
803-6	BALL BEARING (696zz)	1	803-19	DRIVE SPINDLE	1
803-7	REAR PLATE	1	803-19A	RETAINING RING	1
803-8A	SUN GEAR	1	803-20	BALL BEARING (6200z)	2
803-8	ROTOR (6T)	1	803-20A	RETAINING RING	1
804-8	ROTOR (9T)	1	803-21	NOSE HOUSING	1
803-9	ROTOR BLADE	5	803-22	LOCKING BALLS	2
803-10	ROLLER PIN (ø2.5x10)	2	803-23	SPRING	1
803-11	CYLINDER	1	803-24	QUICK CHANGE SLEEVE	1
803-12	FRONT END PLATE	1	803-25	DRAW BOLT DRIVER	1
804-12	FRONT END PLATE(ø34xø6)	1	803-26	CIRCLIP	1
			803-27	SCREW	1
803-13	BALL BEARING (626zz)	1	803-28	WASHER	1
804-13	BALL BEARING (698zz)	1	803-29	ROLLER BEARINGS	1
803-14	WASHER	1			

# THE DESCRIPTION ABOUT USING A PNEUMATIC TOOL

A pneumatic tool is a precise mechanical assembly. Under an easy pneumatic operation, a high performance can be achieved efficiently.

The advantages are as follows:

- (1) small size,
- (2) large working torque,
- (3) long life,
- (4) safety; no electrical shock; no heat generated, and
- (5) low energy consumption.

However, while any kind of pneumatic tool is operating under high speed revolution, the moistures and dirt within the interior of the tool need to be removed. Also, a complete lubrication is required.

After applying periodic maintenance of the pneumatic tool, not only the tool's functions can be enhanced, but also, its life can be prolonged up to 2 times than before.

The best accessories/equipments and the usage.

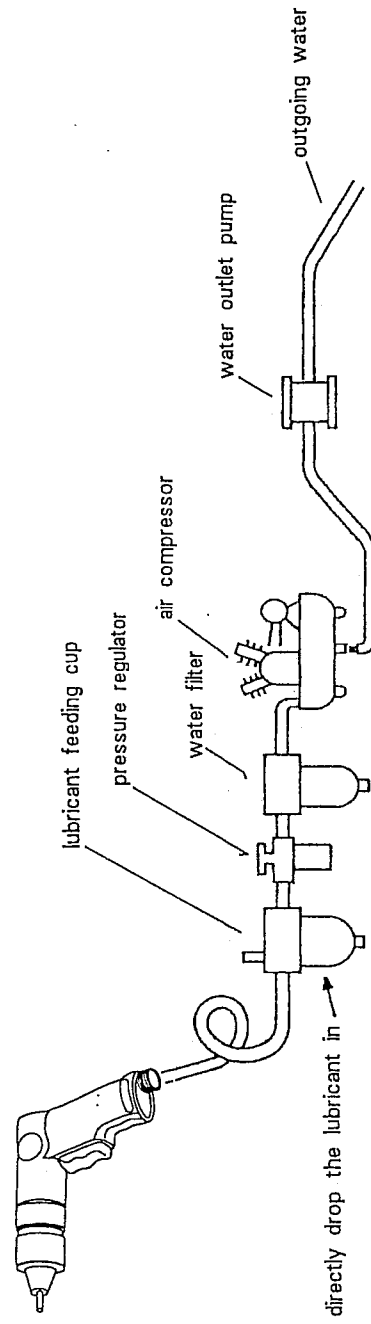

- B. 1. Before a long-term storage of the pneumatic tool, there must be a maintenance for the tool.
2. Drop in approximately 3 to 20 cc (depending on the size of the tool) lubricant into the gas inlet of the pneumatic tool. Usually, when a user presses against the end of trigger, if the lubricant can be seen (as shown in the right illustration), it is completed.
3. Press on the trigger so that the lubricant will flow in and then connect to the high pressure gas about 10 to 20 second operation.
4. Beneath the gas container of the air compressor, a low pressure water pump should be installed.

THREAD SIZE	P.S.I. SETTING REQ'D STATIC	RPM
4—40 UNC	36—40 PSI	<b>3000 RPM</b>
M3 X 0.5	36—40 PSI	
6—32 UNC	75—80 PSI	
8 X 32 UNC	85—90 PSI	
M4 X 0.7	85—90 PSI	

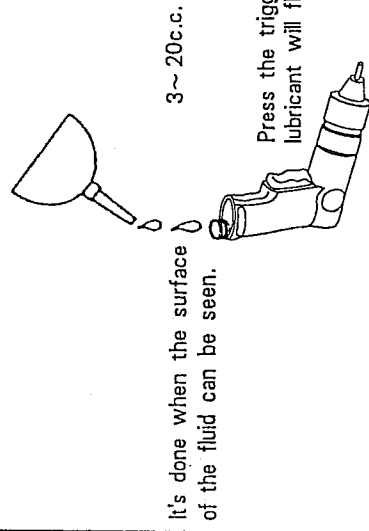

10—24 UNC	85—90 PSI	<b>1500 RPM</b>
10—32 UNF	85—90 PSI	
M5 X 0.8	85—90 PSI	
1/4—20 UNC	95—110 PSI	<b>600 RPM</b>
1/4—28 UNF	95—110 PSI	

5/16—18 UNC	95—110 PSI	<b>600 RPM</b>
5/16—24 UNF	95—110 PSI	
M8 X 1.25	95—110 PSI	<b>600 RPM</b>
3/8—16 UNC	95—110 PSI	
3/8—24 UNF	95—110 PSI	

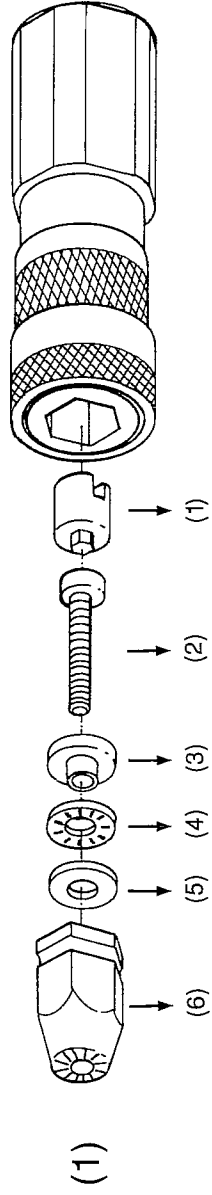

(1) First, assemble the bearing set(part 2,3,4,5) shown as figure.

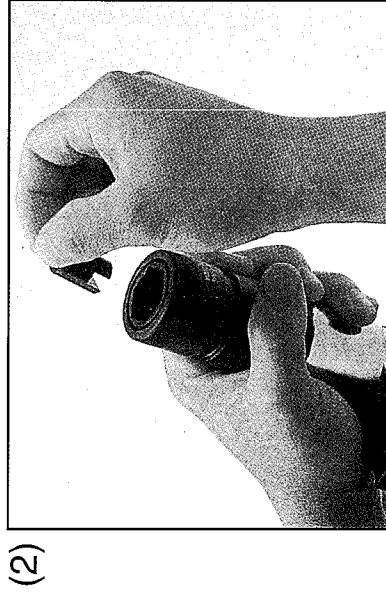

(2)

(2) Insert part 1 into Gun body. Rotate part 1 until the slot connects with Gun body shown as figure.

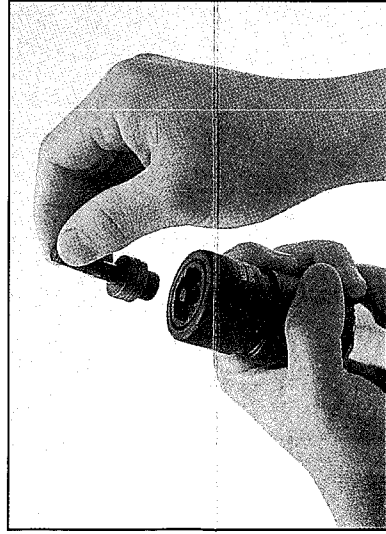

(3)

(3) Install the pre-assembled bearing set with part 1.

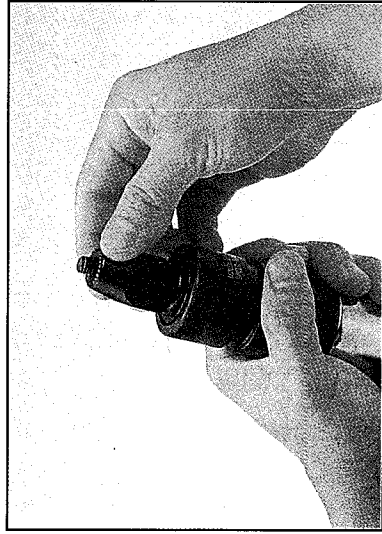

(4)

(4) Insert part 6 into Gun body's hexagon slot.



(5)

(5) Push Gun body's quick releasing ring backward and push part 6 into Gun body completely Release the quick releasing ring to complete the tool assembly.